



THE GROUNDWORX CO.

#2, 1008 17 AVE • NISKU, AB • T9E 0G5
888.222.2670 • WWW.GROUNDWORX.CA



RDO 616 SCREENER (3 DECK)

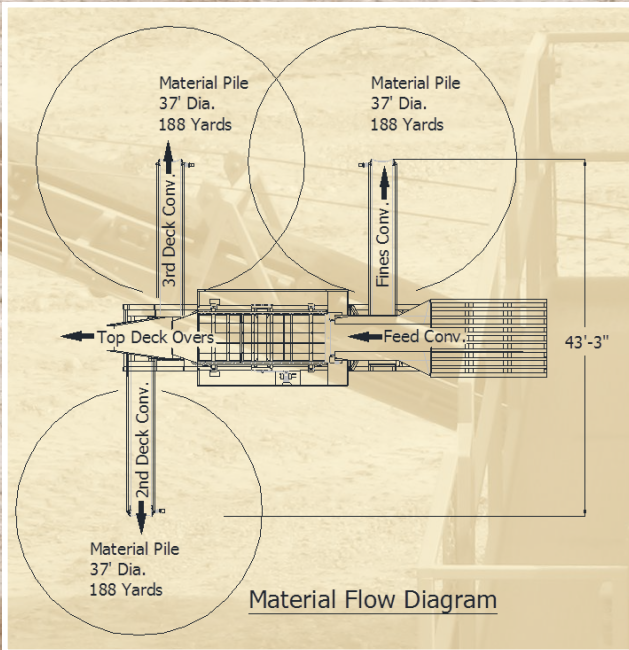

Travel Specifications

Weight At Pin	14,340 lbs.
Weight At Front Axle	11,950 lbs.
Weight At Mid Axle	14,670 lbs.
Weight At Rear Axle	17,480 lbs.
Total weight	58,440 lbs.
Height	13'-6"
Width	11'-11"
Length	54'

Diesel Engine

Manufacturer	Caterpillar
Model	C6.6
E.P.A.	Tier 3 Certified (Tier 4 available)
Turbo	Turbocharged Aftercooled
Horsepower	173hp @ 2200 rpm
Radiator	Upgraded AKG Radiator
Cooling	Water Cooled
Fuel Tank	80 Gallon

Hydraulics

Legs	2 hydraulic Jacking Legs
Aux. Valve	For Off Board Conv. Or Opt. Grizzly Top
Hydraulic Tank	152 Gallon

Feeder Hopper

Standard (Grizzly Ready)	Approx. 15 cu Yards
Wing Wall Hopper (Opt.)	18 Yards
Loading Height	13'-6"

Screen - 6x16x3D Step Deck

Drive - Type	Hydraulic
Drive - Cubic Inch	7.72
Drive - RPM	1150
Screen Throw	5/8"
Suspension	Rubber Spring
Bearings	140mm

Feeder / Grizzly Options

14' Hyd End Dump Grizzly (HEAVY DUTY)

Misc. Options

Single Shaft Soil Shredder

Leg Options

2 Or 4 Rear Hydraulic Legs

Screen Options

Wet Kit

Conveyor Options

Belting Options: 3-Ply, Chevron Cleating, Hot Splice

Conveyors

	Length	Width	Motor	Cubic Inches	F.P.M.
Feed Conveyor	23'-10"	48"	Hyd	19	Vari.
Under Screen Conveyor		60"	Hyd	45	168
Fines Conveyor	16'-4"	30"	Hyd	24	314
2nd Deck Conveyor	16'-4"	30"	Hyd	45	329
3rd Deck Conveyor	16'-4"	30"	Hyd	45	329